

ENW ECONOMY NARROW WRAP SERIES

Shallow economy narrow wraparound 2 lamp and 4 lamp units. Available in 24" and 48" lengths.

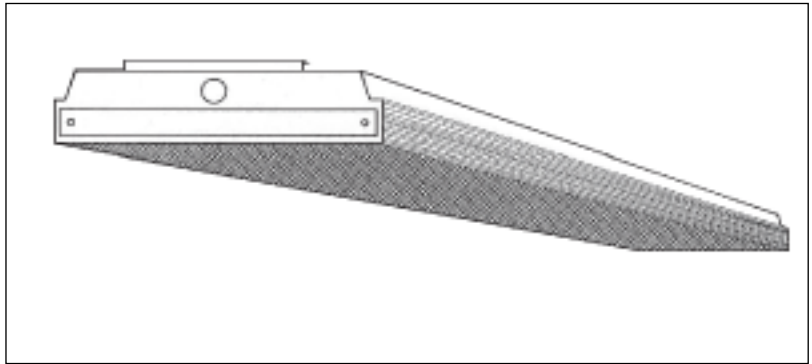

Dimensional Data

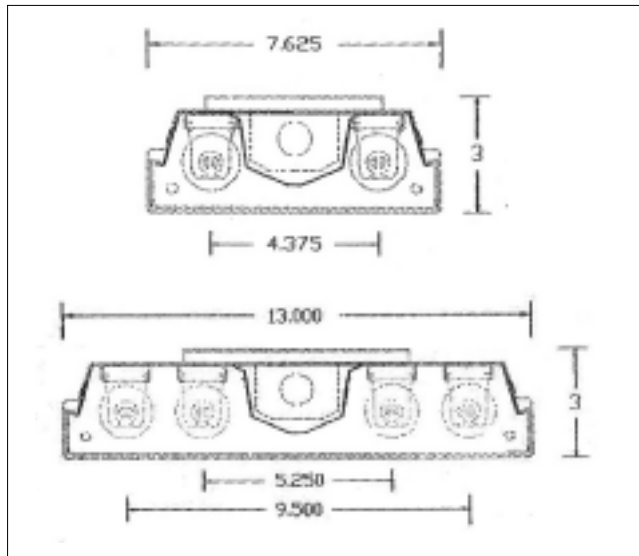

Specifications

Construction: Completely die formed from 22 gauge baked white enamel with ceiling spacer on ends. Sockets mounted onto ends.

Mounting: Individual or continuous run, surface or pendant mount.

Diffuser: Linear sided prismatic lens of extruded acrylic for controlled light. Diffuser is lift and shift for ease of relamping and is capable of hanging down from either side of housing.

Ordering Information

Catalog	Lamp	Size
ENW217A/UV	2-F17T8	7-5/8" X 24"
ENW214A/UV	2-F14T5	7-5/8" X 24"
ENW224HOA/UV	2-FP24T5HO	7-5/8" X 24"
ENW232A/UV	2-F32T8	7-5/8" X 48"
ENW228A/UV	2-FP28T5	7-5/8" X 48"
ENW254HOA/UV	2-FP54T5HO	7-5/8" X 48"
ENW432A/UV	4-F32T8	13" X 48"
ENW428A/UV	4-FP28T5	13" X 48"
ENW454HOA/UV	4-FP54T5HO	13" X 48"

Photometrics: Photometric Information available upon request.

