

VL SERIES

Die cast end caps enhance the stylish appearance of direct/indirect wall valance. Available in either wood grain vinyl or white front baffles to distribute the glow of either one or two lamps. An ideal luminaire for distinctive hallway lighting.

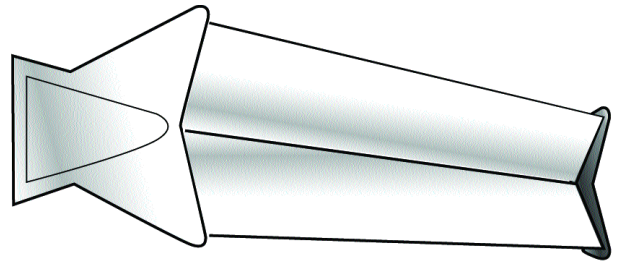

Dimensional Data

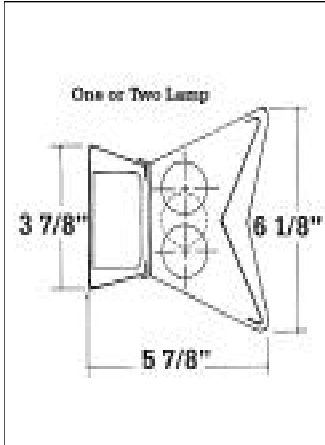

Specifications

Mounting: Back plate provided with adequate knockouts and mounting holes for wall installation.

Construction: Fixture housing is constructed of heavy gauge die-formed steel to maintain uniformity and dimensional stability. Die cast ends with invisible knockouts and decorative embossing. One light and two light units same external dimensions.

Shielding: V-shaped shielding in either simulated woodgrain or white.

Finish: All interior surfaces are electrostatically sprayed with high quality white enamel. Die cast ends are either white or beige to match shielding color.

Wiring: Standard ballast are 120 volt 60 hertz.

Approval: All units are Underwriter's Laboratories (UL) approved.

ORDERING INFORMATION

Catalog # White	Catalog # Walnut	Lamp	Length	Catalog # White	Catalog # Walnut	Lamp	Length
ONE LIGHT MAGNETIC				ONE LIGHT ELECTRONIC OCTRON			
VL120TS	VW120TS	1-F20T12	2'	VL117	VW117	1-FO17T8	2'
VL130ES	VW130ES	1-F30T12	3'	VL125	VW125	1-FO25T8	3'
VL140ES	VW140ES	1-F40	4'	VL132	VW132	1-FO32T8	4'
TWO LIGHT MAGNETIC				TWO LIGHT ELECTRONIC OCTRON			
VL220TS	VW220TS	2-F20T12	2'	VL217	VW217	2-FO17T8	2'
VL230ES	VW230ES	2-F30T12	3'	VL225	VW225	2-FO25T8	3'
VL240ES	VW240ES	2-F40	4'	VL232	VW232	2-FO32T8	4'

Installation Data

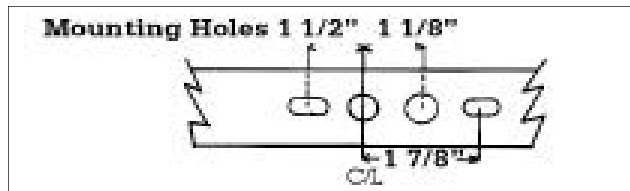

Photometrics

Photometric Information available upon request.

Options and Accessories *Add Suffix*

- EB Electronic T12
 - * CW Low Temperature (0) ballast
 - * DIM Dimming ballast
 - EM Emergency ballast (1 lamp)
 - EM/2Emergency ballast (2 lamp)
 - RFI Radio interference filter
 - FS External fuse and holder
 - SW4 4-way switch (2 ballast)
- * Available Magnetic T12 or Electronic T8.
•Note: Consult factory on compatibility EM/2 option.

