

600 SERIES

A square, architecturally inspired, milk white diffuser, highlighted by a stylish white trim, which evenly distributes the light of both circleline and miniature twin tube lamps

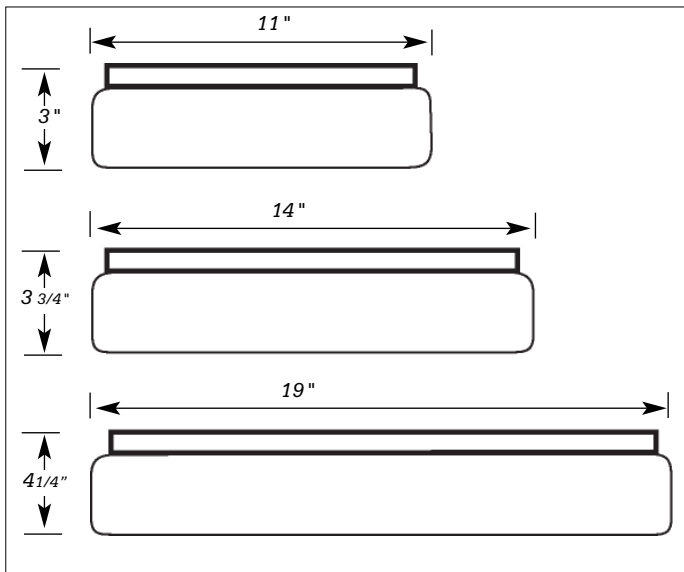

Dimensional Data



Specifications

Mounting: Back Plate provided with adequate knockouts and mounting holes for either wall or ceiling installation.

Construction: All metal parts are die formed from heavy gauge cold rolled steel. Exterior finish high quality white enamel.

Diffuser: One piece .125 smooth opal acrylic for a fully luminous light source.

Wiring: Circleline ballast are ETL-CBM, Class P ROV. HPF Standard on 22-32 watt units. All PL ballast normal power factor. High power factor ballast available upon request.

Approval: All units are Underwriter's Laboratories (UL) approved.

Ordering Information

Catalog #	Lamp	Size	Catalog #	Lamp	Size
CIRCLELINE			MINIATURE TWIN TUBES		
White Finish			White Finish		
6102	22w	11"x11"	6102/PL7	1-PL7	11"x11"
6103	32w	14"x14"	6102/PL9	1-PL9	11"x11"
6105H	22w, 32w	14"x14"	6102/PL13	1-PL13	11"x11"
6107	32w, 40w	19"x19"	6102/2PL7	2-PL7	11"x11"
6104	40w	19"x19"	6102/2PL9	2-PL9	11"x11"
			6102/2PL13	2-PL13	11"x11"
			6103/2PL7	2-PL7	14"x14"
			6103/2PL9	2-PL9	14"x14"
			6103/PL13	1-PL13	14"x14"
			6103/2PL13	2-PL13	14"x14"
			6103/3PL13	3-PL13	14"x14"
			6104/3PL13	3-PL13	19"x19"

Available with Black Base. Add suffix BL to catalog number.

Photometrics: Photometric Information available upon request.



600 SERIES

Installation Data

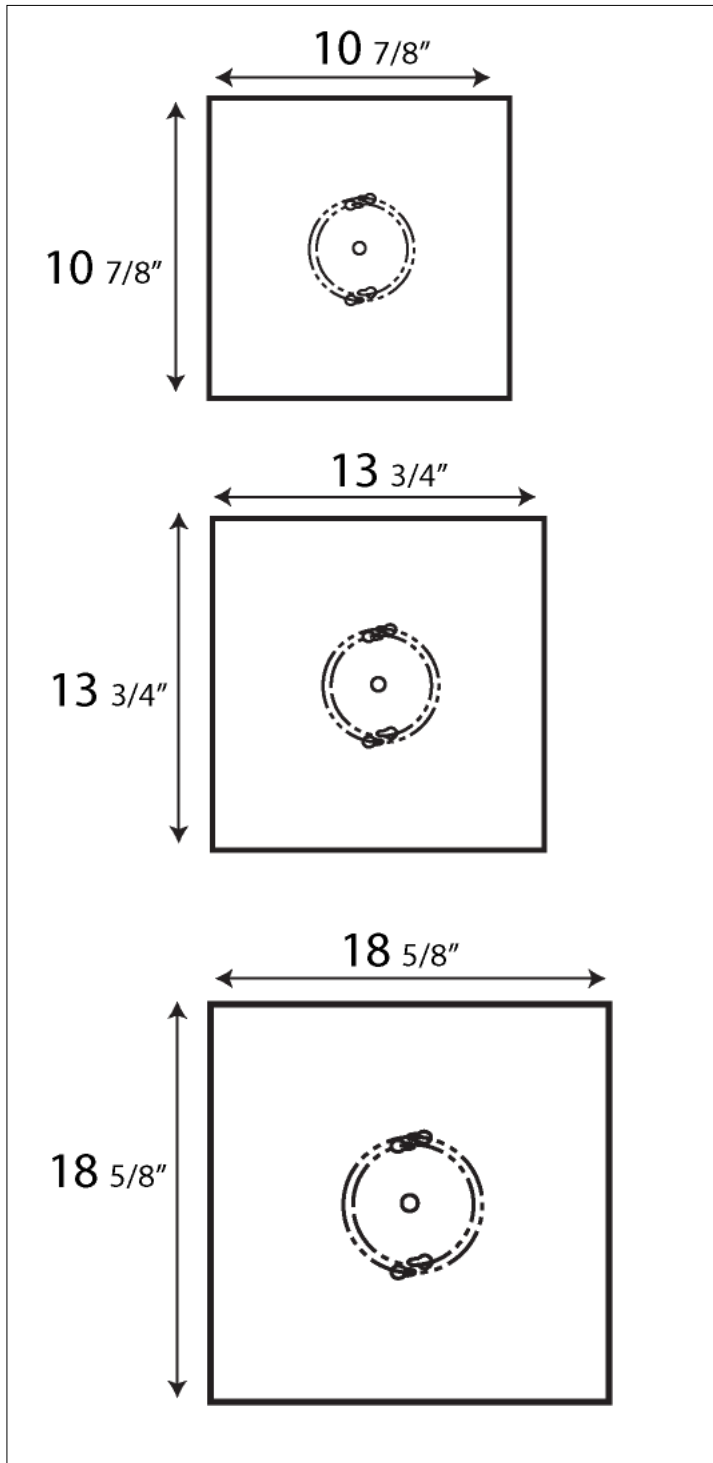

NEW ENGLAND
LIGHTING
INCORPORATED