

STAGGERED STRIP TWO LAMP SERIES

Specially designed open strip channels with overlapping lamps to provide continuous uninterrupted illumination. Available in lengths from 18" to 96" and is ideal lighting for coves and valances.

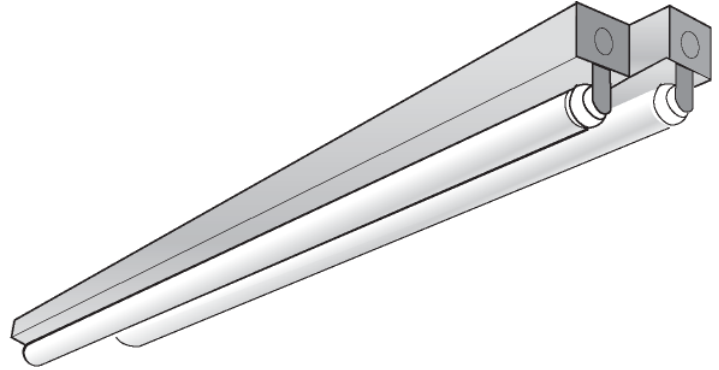

Dimensional Data

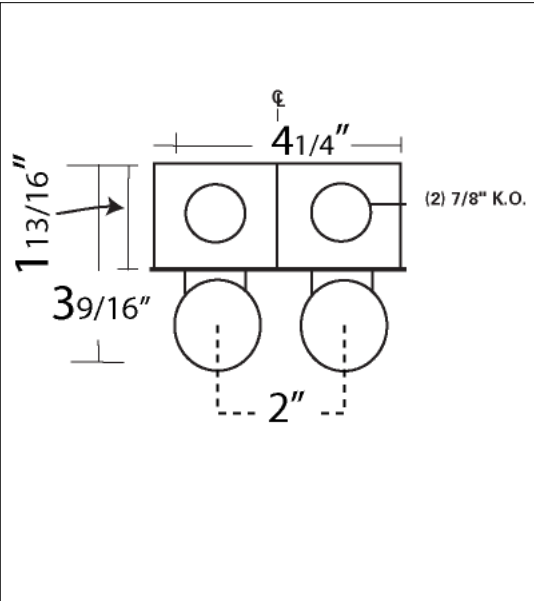

Specifications

Mounting: Fixtures may be ceiling or wall mounted individually or in continuous rows. When mounting in rows, turn end cap ninety degrees for joiner strap.

Construction: Housing is die formed of heavy gauge steel designed for maximum strength and uniformity. Wiring components are mounted in the one piece back housing, permitting the removal of the cover for maintenance or cleaning without disturbing any of the inner wiring.

Finish: All metal parts are cleaned and treated to prevent rust with a phosphate coating applied automatically in a five stage process. All parts are electrostatically sprayed with high quality white enamel to provide a minimum reflectance of 87%.

Wiring: All ballast 120 volt.

Approval: All units are Underwriter's Laboratories (UL) approved.

Ordering Information

Catalog #	Lamp	Catalog #	Lamp	Length
ELECTRONIC T12		ELECTRONIC OCTRON T8		
SM215STGEB	2-F15T12			21"
SM220STGEB	2-F20T12	SM220STGEB	2-F17T8	27"
SM230STGEB	2-F30T12	SM230STGEB	2-F25T8	39"
SM230TSTGEB	4-F30T12	SM230TSTGEB	4-F25T8	75"
SM240STGEB	2-F40T12	SM240STGEB	2-F32T8	51"
SM240TSTGEB	4-F40T12	SM240TSTGEB	4-F32T8	99"

Photometrics: Photometric Information available upon request.



STAGGERED STRIP TWO LAMP SERIES

Options and Accessories *Add Suffix*

EB	Electronic T12
*CW	(Note 1,2) Low Temperature (0) Ballast
*DIM	Dimming Ballast
EM	Emergency Ballast (1 lamp)
•EM/2	Emergency Ballast (2 lamp)
RFI	Radio Interference Filter
FS	External Fuse and Holder
CORD-3W	6' 3 Wire Cord and Plug

Installation Data

