

OPEN CIRCLELINE SERIES

A variety of Circleline combinations on either white enamel or polished chrome fixtures provide the energy and maintenance savings alternative to incandescent lighting. Ideally suited for kitchens, hallways, and utility areas.

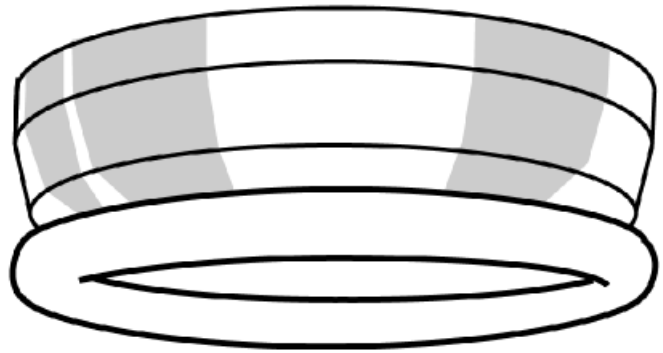

Dimensional Data

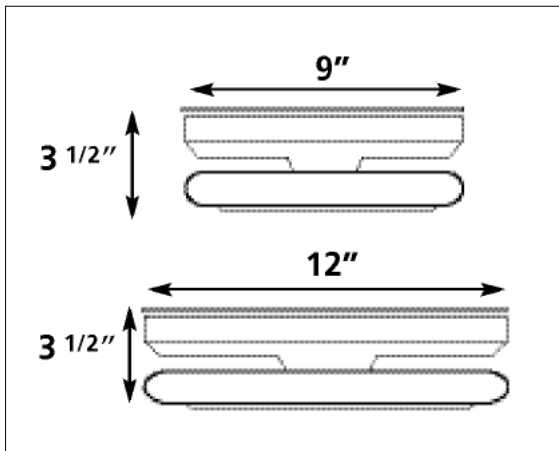

Specifications

Construction: Fixture housings are die formed of heavy gauge cold rolled steel to insure uniformity and dimensional stability.

Finish: Exteriors available in either high quality white enamel or polished chrome.

Wiring: All ballasts are high power factor class "P". Standard voltage 120 volts.

Approval: All units are Underwriter's Laboratories (UL) approved.

Ordering Information

White	Chrome	Lamps	Diameter
ELECTRONIC T12			
CW22EB	CL22EB	1-22w	9"
CW32EB	CL32EB	1-32w	12"
CW22-32EB	CL22-32EB	1-22w - 1-32w	12"

Photometrics: Photometric Information available upon request.

