

TS SERIES MIDGET STRIP

Midget fluorescent strips in a variety of lengths and lamp sizes are ideally suited for those limited hard-to-light areas. A perfect luminaire for display cabinets, showcases, and bookcases. Matching reflectors available.

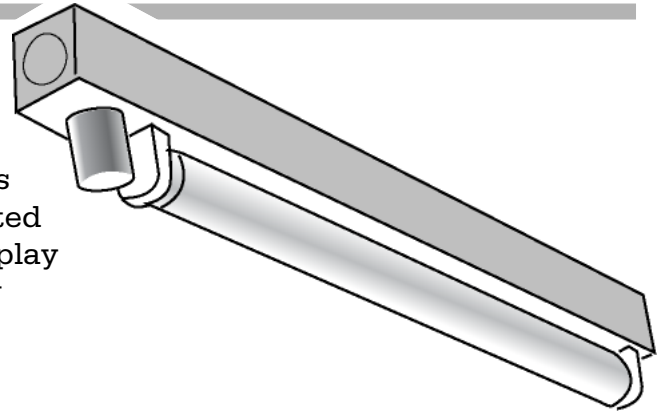

Dimensional Data

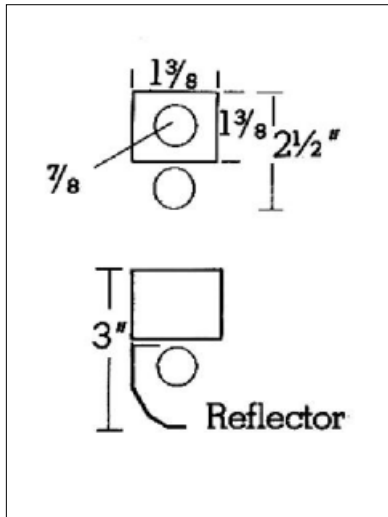

Specifications

Construction: All metal parts die-formed of heavy gauge cold rolled steel to insure uniformity and dimensional stability.

Finish: All metal components are phosphate coated and electro-statically sprayed with a high quality baked white enamel with a minimum reflectance of 87%.

Wiring: All units preheat (starter required). 120 volts (Other voltages available upon request).

Approval: All units are Underwriter's Laboratories (UL) approved.

Ordering Information

Catalog #	Lamp	Length	Matching Reflector
TS4	1-F4T5	9"	R4
TS6	1-F6T5	12"	R6
TS8	1-F8T5	15"	R8
TS15	1-F15T8	21"	R15
TS215	2-F15T8	40 1/2"	R215
TS315	3-F15T8	61"	R315

Installation Data

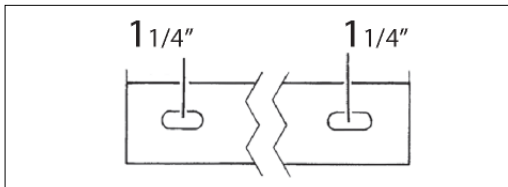

Photometrics

Photometric Information available upon request.

NEW ENGLAND
LIGHTING
INCORPORATED